

Client \_\_\_\_\_ Quantity \_\_\_\_\_  
 Project \_\_\_\_\_ Position \_\_\_\_\_

## REFRIGERATION

Model: TS16/1MR-490-07

Cod: HT10380000214

### Technical data

Modularity:	Without top
Dimensions (mm):	1600x680x590
Total electric power (kW):	0,81
Electric power (V):	220-240
Ampere (A):	3,7
Frequency (Hz):	50-60
Net volume (m3):	0,642
Packing dimensions (mm):	1875x800x998
Gross weight (kg):	95
Gross volume (m3):	1,500

### Features

Grill:	Plastic coated GN1/1
Working top:	Special for overlapping kitchen top modules Roc
Handles:	AISI 304 stainless steel, 2 mm thick
Drawer guides:	Full extension

2-door refrigerated base unit, remote engine. Made entirely of AISI 304 110/10 stainless steel with 60 mm thick insulation obtained with CFC and HCFC-free polyurethane resins. Reversible self-closing doors with 105° stop, equipped with triple chamber geometry gasket with D7 compound. Ventilated refrigeration controlled by digital thermostat. Automatic electric defrosting system and elimination of condensation water by means of the heat dissipated by the refrigerant system. Operation in Climatic Class 5. Set up for R452A gas operation. Temperature -2°/+8° C. Power: 0.85 kW. Voltage: 220-240V/1N/50Hz. Fixing kit to cookign element included. Engine not included

**Technical draw**

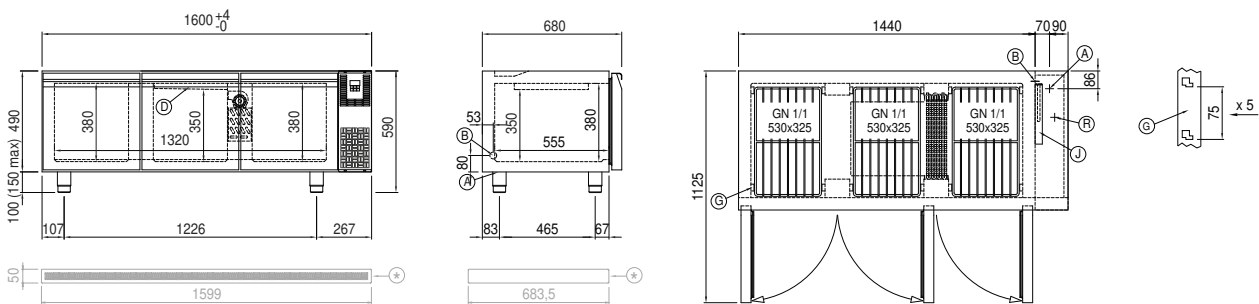

⊕ Telaio di supporto su misura disponibile separatamente / Custom support frame available separately  
MaßgefertigterTragrahmen separat erhältlich / Châssis de support sur mesure disponible séparément  
Bastidor de soporte a medida disponible por separado

G: Gas connection 1/2"